

Job Name/Location:

Tag No.:

Date:

For:	File	Resubmit
	Approval	Other_____

PO No.:

Architect: GC:

Engr: Mech:

Rep: (Company) (Project Manager)



## PLDCAA0S R32 Alarm Kit



### Features:

- For use with LG Single-Zone, Multi F™ / Multi F MAX, and Multi V™ indoor units that include an R32 leak detection sensor.
- Embedded harness included in alarm kit connects to indoor unit terminal block.
- Requires four-wire, 22 AWG wiring for daisy chaining multiple alarm kits in a system (field supplied).
- Can install up to eight (8) alarm kits in a system.

### Sequence of Operations

(Alarm must be activated via the refrigerant leak detector included in those compatible indoor units):

1. Leak detected at indoor unit.
2. Indoor unit fan operates.
3. Leak alarm activates.
4. Error code displays at remote controller.
5. Outdoor unit stops operating.

### Electrical:

Power Supply	5 VDC Power from Indoor Unit
MCA	1
Contact Rating	DC 5V
Alarm Rated Voltage	5.0 VDC (4.75 – 5.25 ± 5%)
Alarm Average Power Consumption	20 mA

### Notes:

1. Wiring between alarm kit to alarm kit is to be 22 AWG, four-conductor, twisted, stranded, shielded. Wiring must comply with all applicable local and national codes.

### Surrounding Conditions:

Operating Temperature	-40 ~ +185°F
Storage Temperature	-22 ~ +185°F
Humidity	15 ~ 85 % RH

### Connectivity:

Wiring Length	Maximum 164 ft. (50m)
---------------	-----------------------

### Unit Data:

Housing Material	ABS
Noise Level (Sound Pressure, 9.84 ft. [3m])	70 dB(A)
Net Dimensions	
Front Cover (W x H x D, in.)	3-5/32 x 4-21/64 x 1-43/64
Back Plate (W x H x D, in.)	3-5/32 x 4-21/64 x 1-9/32
Alarm Component (W x H x D, in.)	1-3/8 x 1-31/32 x 1-1/32
Shipping Dimensions (W x H x D, in.)	10-5/8 x 6-7/32 x 2-33/64
Net Weight (lbs.)	0.265
Shipping Weight (lbs.)	0.9

2. Alarm kit components must be kept dry and free of debris before installation.
3. Must follow instructions in the applicable LG installation manual.

### System Wiring Schematic:

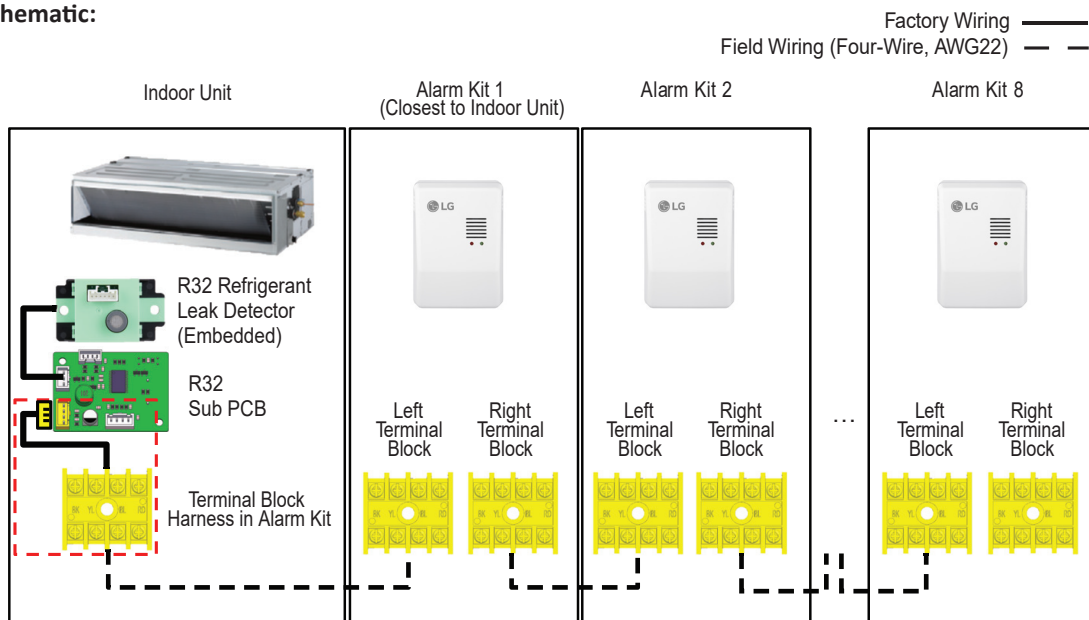

For a complete list of available accessories, contact your LG representative.

For continual product development, LG reserves the right to change specifications without notice.

SB\_Alarm\_Kit\_R32\_PLDCAA0S\_2025\_05\_22\_060730

© LG Electronics U.S.A., Inc., Englewood Cliffs, NJ. All rights reserved. "LG Life's Good" is a registered trademark of LG Corp. /www.lghvac.com

**PLDCAA0S**  
**R32 Alarm Kit**



### Front Cover

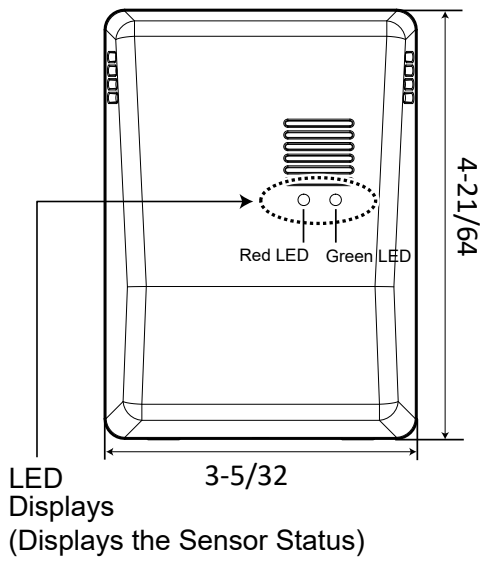

### Back Plate

