

Job Name/Location:

Tag No.:

Date:

For:	File	Resubmit
	Approval	Other

PO No.:

Architect: GC:

Engr: Mech:

Rep: (Company) (Project Manager)



KSUAB121A
R32 Single Zone High Efficiency Wall Mounted
 Outdoor Unit (ODU) - KUSAB121A, Indoor Unit (IDU) - KNUAB121A

Performance:

Cooling Capacity (Min~Rated~Max, Btu/h)	1,023 ~ 12,000 ~ 14,100
SEER2	22.5
EER2	12.80

SEER - Seasonal Energy Efficiency Ratio EER - Energy Efficiency Ratio

Heating Capacity (Min~Rated~Max, Btu/h)	1,023 ~ 13,600 ~ 19,040
HSPF2	10.5
Max. Heating @ Indoor 70°F DB (Btu/h)	
Outdoor 17°F WB	12,400 (91%)
Outdoor 5°F WB	10,000 (74%)
Outdoor -4°F WB	8,010 (59%)

HSPF - Heating Seasonal Performance Factor Heating Nominal Test Conditions:
 Cooling Nominal Test Conditions: Indoor: 70°F DB / 60°F WB
 Indoor: 80°F DB / 67°F WB Outdoor: 47°F DB / 43°F WB
 Outdoor: 95°F DB / 75°F WB

Electrical:

Power Supply (V~/Hz/Ø)	208-230 / 60 / 1
MOP (A)	15
MCA (A)	12
Cooling / Heating Rated Amps (A)	8.7
Compressor (A)	8.3
Fan Motor (IDU + ODU) (A)	0.4 + 0.4
Cooling Power Input (Min~Rated~Max, kW)	0.20 ~ 0.93 ~ 1.60
Heating Power Input (Min~Rated~Max, kW)	0.19 ~ 1.04 ~ 1.97
Locked Rotor Amps (A)	9.0

MOP - Maximum Overcurrent Protection MCA - Minimum Circuit Ampacity

Piping:

Installed Liquid Pipe (in., O.D.)	1/4 Flare
Installed Vapor Pipe (in., O.D.)	3/8 Flare
IDU Liquid Connection (in., O.D.)	1/4 Flare
IDU Vapor Connection (in., O.D.)	3/8 Flare
Additional Refrigerant (oz./ft.)	0.16
Min. / Max. Pipe Length (ft.) ²	9.8 / 82
Piping Length (no add'l refig., ft.)	41
Max. Elevation (ft.)	49.2

Features:

- Inverter (Variable Speed Compressor)
- 24-Hour on/off timer
- 4-Way auto swing
- Sleep Mode
- Jet Cool/Jet Heat
- Auto Restart
- Auto Changeover
- Built-in Drain pan heater
- Built-in Wi-Fi via ThinQ app
- Smart Diagnosis
- 3M Micro Filter
- IDU compatible with Multi F ODUs
- Low ambient cooling down to 14°F (0°F with Wind Baffle Kit)
- Self-cleaning indoor coil
- IDU R32 leak detection sensor

Included Accessories:

- Wireless Remote Controller — AKB76044208

Optional Accessories:

- PI-485 - PMNFP14A1
- R32 Alarm Kit - PLDCAA0S
- Low Ambient Wind Baffle (Cooling to 0°F) - ZLABGP01A

Controller Options:

- MultiSITE™ CRC* Controllers
- Standard III Remote Controllers
- Dry Contacts
- AC Smart 5 Central Controller
- LonWorks® Gateway
- MultiSITE Comm. Mgr.
- AC Smart BACnet® Gateway

Operating Range:

Outdoor Unit:	
Cooling (°F DB)	14 ~ 118
Heating (°F WB)	-4 ~ +65

Indoor Unit:	
Cooling (°F WB)	53 ~ 75
Heating (°F DB)	60 ~ 86

System Data:

Refrigerant Type	R32
Refrigerant Control	EEV
Refrigerant Charge (lbs.)	1.81
ODU Sound Pressure (Cooling / Heating) (±1 dB[A]) ³	47 / 51
IDU Sound Pressure	
Cooling (H/M/L/SL) (±1 dB[A]) ³	41 / 35 / 25 / 21
Heating (H/M/L) (±1 dB[A]) ³	41 / 35 / 26
ODU Net / Shipping Weight (lbs.)	68.8 / 75.6
IDU Net / Shipping Weight (lbs.)	19.73 / 22.7
Heat Exchanger Coating	GoldFin™

Fan:

ODU Type	Propeller
IDU Type	Cross Flow
Fan Speeds (Fan/Cool/Heat)	6 / 6 / 6
Quantity (ODU + IDU)	1 + 1
Motor/Drive	Brushless Digitally Controlled / Direct
Maximum ODU Air Volume (CFM)	1.165
IDU Air Flow	
Cooling, Max/H/M/L (CFM)	459 / 388 / 318 / 194
Heating, Max/H/M/L (CFM)	459 / 388 / 318 / 229
Dehumidification (pts./hr.)	2.75

Notes:

- Acceptable operating voltage: 187V-253V.
 - Piping lengths are equivalent.
 - Sound Pressure levels are tested in an anechoic chamber under ISO Standard 3745.
 - All power supply wiring to the outdoor unit is field supplied, solid or stranded. The power wiring and the communication wiring from the outdoor unit to the indoor unit is field supplied and must be stranded, shielded or unshielded (if shielded, it must be grounded to the chassis of the outdoor unit only). All wiring must comply with applicable local and national codes.
 - Power Supply Wiring to ODU: (No. x AWG): 3 x 14 for 9/12k, 3 x 12 for 18k units.
 - Power Wiring / Communication Wiring from Outdoor Unit to Indoor Unit: (No. x AWG) 3 x 14 / 2 x 18.
 - See Engineering Manual for sensible and latent capacities.
 - Power wiring cable size must comply with the applicable local and national code.
 - The indoor unit comes with a dry helium charge.
 - This data is rated 0 ft. above sea level, with 24.6 ft. of refrigerant line and a 0 ft. level difference between outdoor and indoor units.
 - Must follow installation instructions in the applicable LG installation manual.
 - Multi-compatible 18k IDUs include socket adapters for refrigerant pipe connections with Multi F systems.
- BACnet® is a registered trademark of ASHRAE. LonWorks® is a trademark of Echelon Corporation.



Proper sizing and installation of equipment is critical to achieve optimal performance. Split system air conditioners and heat pumps (excluding ductless systems) must be matched with appropriate coil components to meet ENERGY STAR® criteria. Ask your contractor for details or visit www.energystar.gov. (ENERGY STAR and the ENERGY STAR mark are registered trademarks owned by the U.S. Environmental Protection Agency.)

For a complete list of available accessories, contact your LG representative.

For continual product development, LG reserves the right to change specifications without notice.

© LG Electronics U.S.A., Inc., Englewood Cliffs, NJ. All rights reserved. "LG Life's Good" is a registered trademark of LG Corp. /www.lghvac.com

Job Name/Location: _____

KSUAB121A

R32 Single Zone High Efficiency Wall Mounted

Outdoor Unit (ODU) - KUSAB121A, Indoor Unit (IDU) - KNUAB121A



Tag No.: _____

Date: _____

PO No.: _____

Unit : inch (mm)

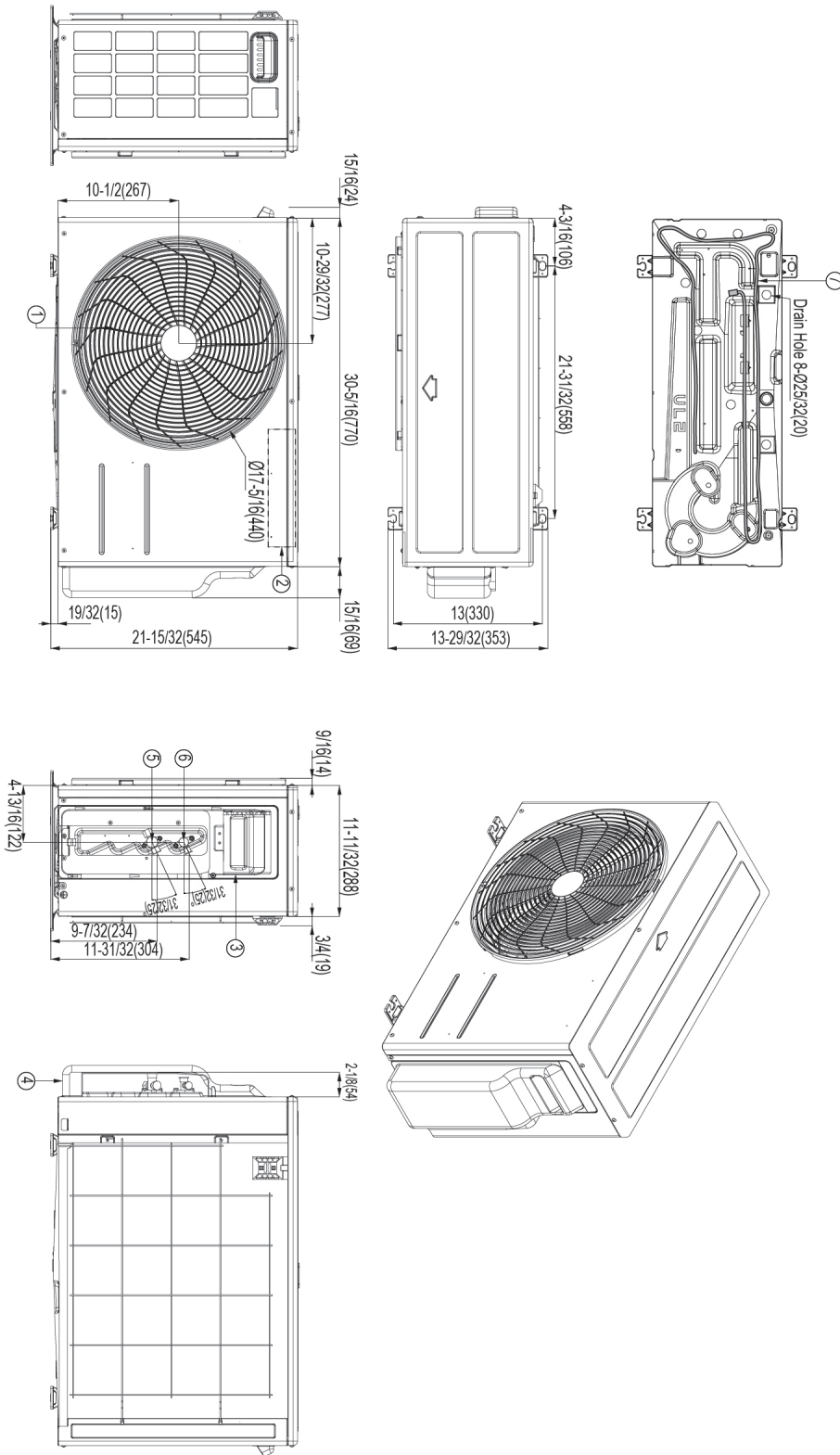

No	Name	Description
7	Sump Heater	
6	Liquid Pipe Connection	Flare Joint
5	Gas Pipe Connection	Flare Joint
4	Service Valve Cover	
3	Power and Communication Cable Hole	
2	Control Box	
1	Air Outlet	

Job Name/Location: _____

KSUAB121A

R32 Single Zone High Efficiency Wall Mounted

Outdoor Unit (ODU) - KUSAB121A, Indoor Unit (IDU) - KNUAB121A



Tag No.: _____

Date: _____

PO No.: _____

Unit : inch (mm)

